

ZXLD1321EV1 USER GUIDE

DESCRIPTION

The ZXLD1321 is an inductive DC-DC converter, with an internal switch, designed for driving single or multiple LEDs in series up to a total of 1A output current.

Applications cover commercial environments with input voltages ranging from 1.2V to 12V.

The device employs a variable 'on' and 'off' time control scheme with adjustable peak switch current limiting and supports step-up (Boost) mode and self-powering Bootstrap operating modes, offering higher power efficiency and lower system cost than conventional PFM circuitry.

The device includes the DC-DC converter, a high-side current monitor and an NPN switching transistor to provide an integrated solution offering small PCB size, competitive cost/performance, high power efficiency of DC-DC conversion and maximum LED brightness/reliability. More importantly, it retains design flexibility to add customer specific features

The feedback control circuitry inside the ZXLD1321 provides excellent load and current regulation, resulting in very stable LED current over the useful life of the battery and over the full operating temperature range.

The LED current can be adjusted from 100% down to 10% of the set value by applying a dc voltage to the ADJ pin and down to 1% by applying a PWM signal to the ADJ pin. An on-chip LED protection circuit also allows output current to be reduced linearly above a predetermined threshold temperature using an external thermistor at the TADJ pin.

External resistors set nominal average LED current and coil peak current independently.

The device can be shut down by applying a continuous low level dc voltage to the ADJ pin.

FEATURES

- 1.2V to 12V Input Voltage Range
- Up to 1A output current
- Typical efficiency (*) : >85%
- Bootstrap operation enables input voltage down to 1V
- User-defined thermal control of LED output current using external thermistor
- 12µA typical standby current
- Adjustable Soft-Start
- Drives up to 5 white LEDs in series

ORDERING INFORMATION

ORDER NUMBER
ZXLD1321EV1

Please note evaluation boards are subject to availability and qualified leads.

APPLICATIONS

- High power LED flashlights
- LED back-up lighting
- General LED lighting

TYPICAL APPLICATION CIRCUIT

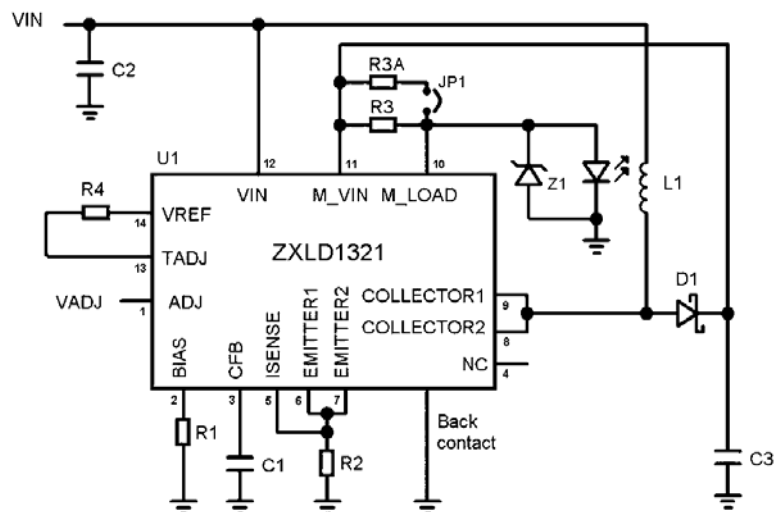

REFERENCE DESIGN

The ZXLD1321EV1 is configured to the reference design below. The target application is 700mA/1000mA high current LED driver for single or multiple LEDs with wide input voltage range.

If the ZXLD1321EV1 is connected to 1 off-board LED, the supply voltage is: VIN=2V ~ 3.4V.

The ZXLD1321EV1 boards are initially set at LED current of around 700mA with 150mΩ (R3) current sensing resistor. In order to boost the LED current to 1000mA, the on-board 300mΩ (R3A) could be made parallel to R3 by means of soldering jumper pad JP1.

For other reference designs or further applications information please refer to the ZXLD1321 datasheet.

SCHEMATIC DIAGRAM

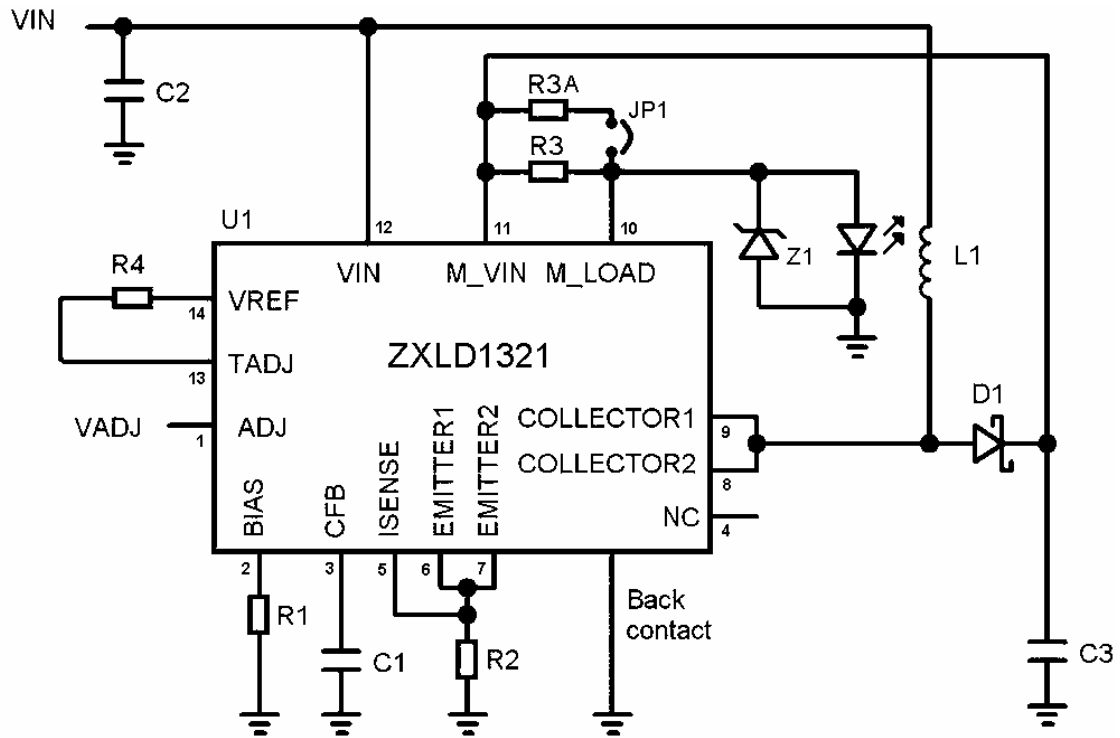

Materials List

Ref	Value	Package	Part Number	Manufacturer	Contact Details
U1	LED Driver	DFN14	ZXLD1321DCA	Zetex	www.zetex.com
D1	Schottky Diode	SOT23-6	ZHCS2000	Zetex	www.zetex.com
L1	10uH 2A		MSS7341-103ML NPIS64D100MTRF 744-777910	Coilcraft NIC Comps. Würth	www.coilcraft.com www.niccomp.com www.we-online.com
C1	10nF 10V	0603	Generic	Generic	
C2	2.2uF 25V	1206	GRM31MR71E225K	Murata	www.murata.com
C3	4.7uF 50V	1206	GRM31CR71H475K	Murata	www.murata.com
R1	430Ω	0805	Generic	Generic	
R2	25mΩ	0603	Generic	Generic	
R3	150mΩ	0805	Generic	Generic	
R3A	300mΩ	0805	Generic	Generic	
R4	5.1KΩ	0603	Generic	Generic	
Z1	18V 3W Zener	DO-214AC	BZG03C18	Vishay	www.vishay.com

PERFORMANCE

Graphs

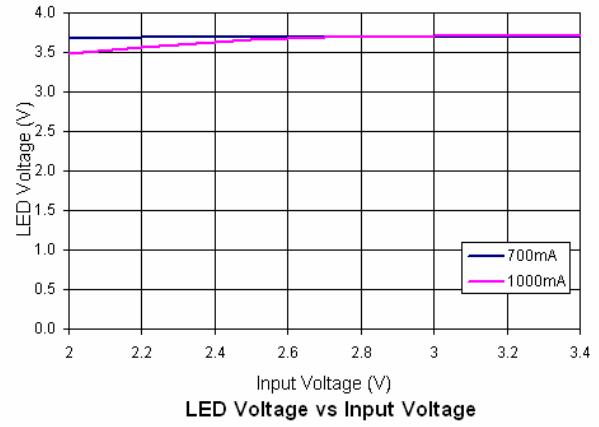
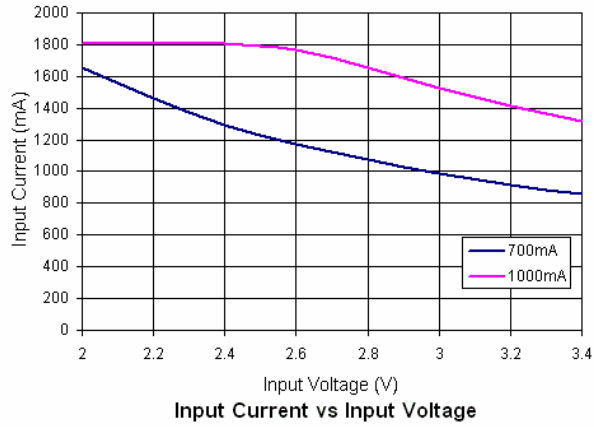
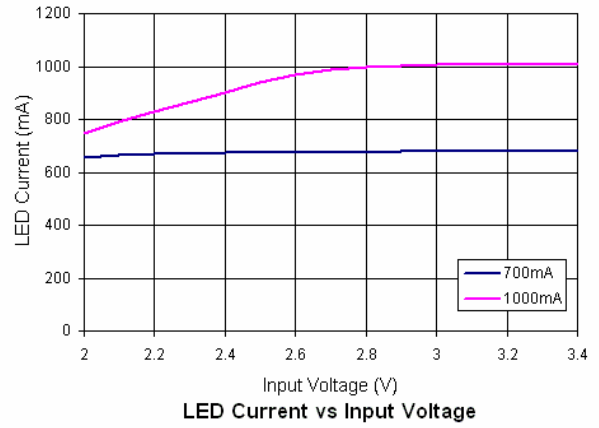
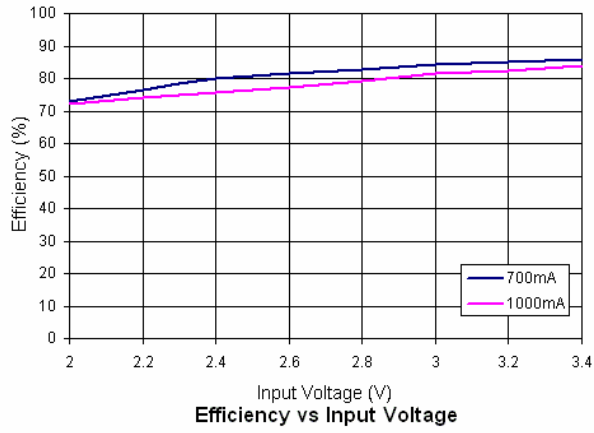

ZXLD1321EV1 OPERATION

Connection diagram

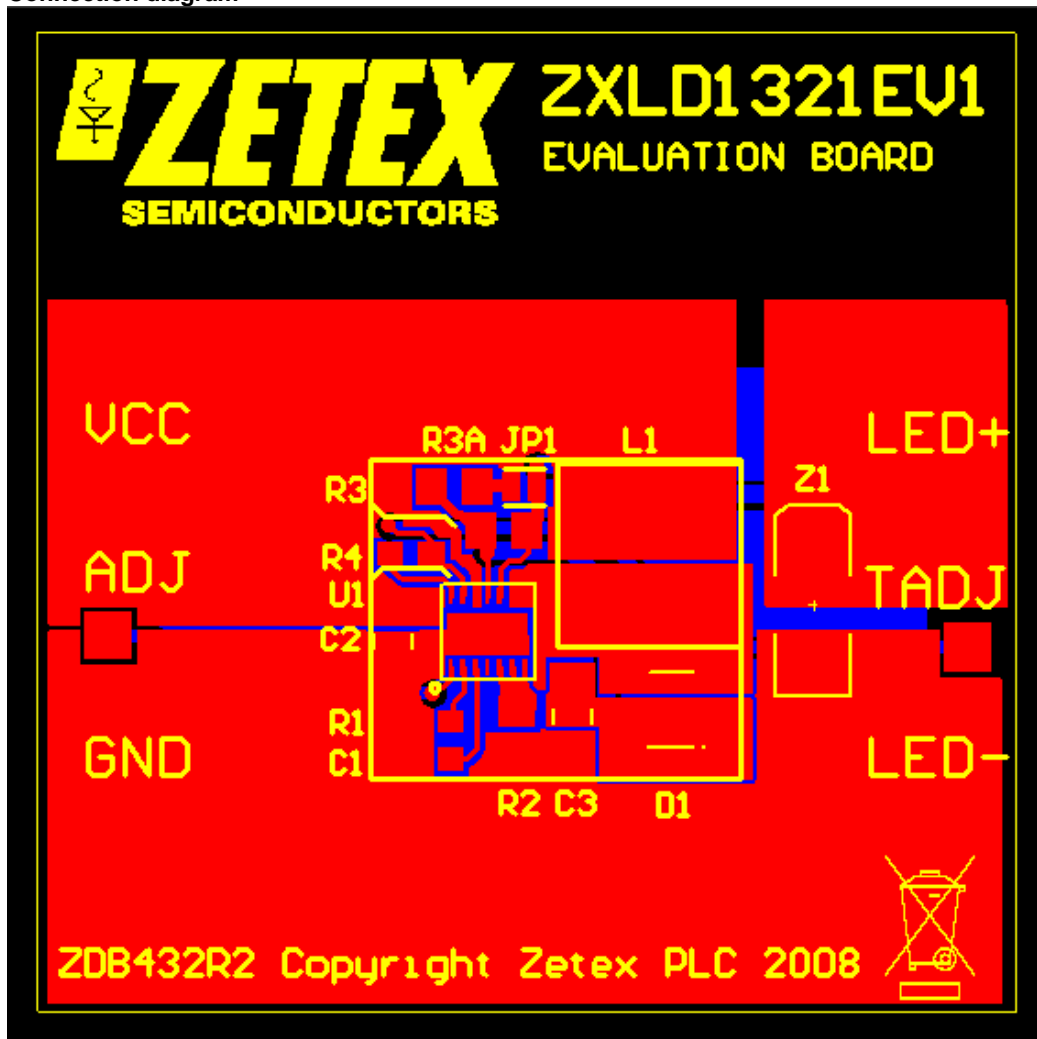
**ZXLD1321EV1 Set-up and Test**

1. Preset the PSU to 3V with a current limit of around 1.8A
2. Connect LED+ and LED- to the Anode and Cathode respectively, of the off-board high power LED .
3. Connect V_{IN} and GND to positive and zero volts of the PSU supply respectively.
4. Set the PSU to 3V.
5. Turn on the PSU.
6. The LED should illuminate and be regulated at 700mA/1000mA +/-5%.
7. The input current should measure between 0.9A and 1.1A for the 700mA option, and between 1.4 A and 1.6A for the 1A option.

Caution: Please make sure the LED is properly connected before applying power. A LED with an appropriate current rating should be used.

Layout considerations

The PCB tracks should be kept as short as possible to minimize ground bounce, and the ground pin of the device should be soldered directly to the ground plane. It is particularly important to mount the coil and the input/output capacitors close to the device to minimize parasitic resistance and inductance, which will degrade efficiency. Precautions should be taken to avoid noise entering the VIN pin. Input decoupling capacitor C2, between VIN and GND, should be kept as close as possible to the device. Enough copper should be attached to the GND pin (exposed pad) for heat-sinking purposes. In this evaluation board, the copper area is on the bottom layer, connected to the exposed pad through several vias.

Below is the recommended layout of the ZXLD1321EV1.

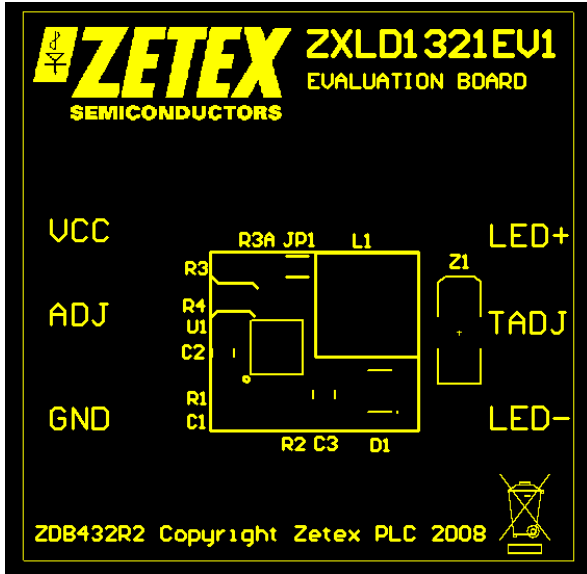

Top Silk

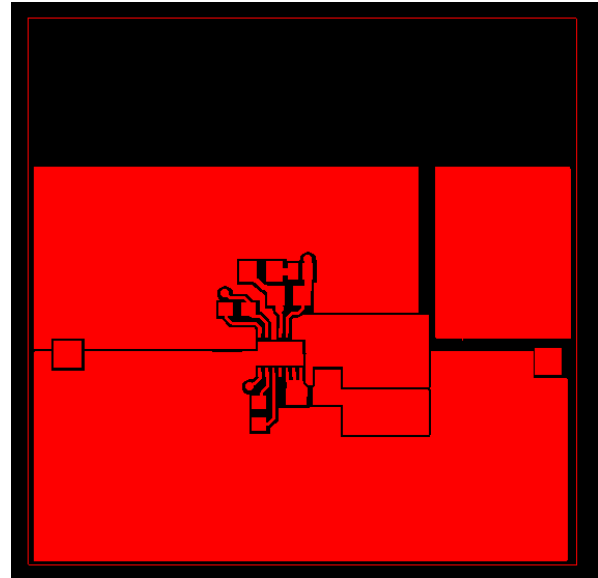

Top Copper

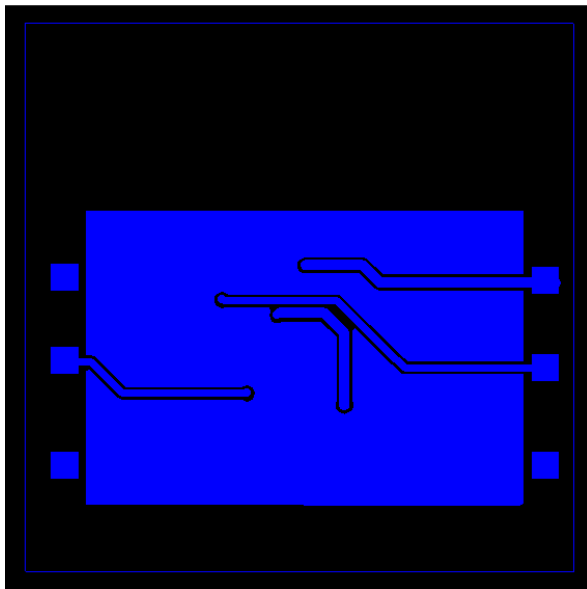

Bottom Copper

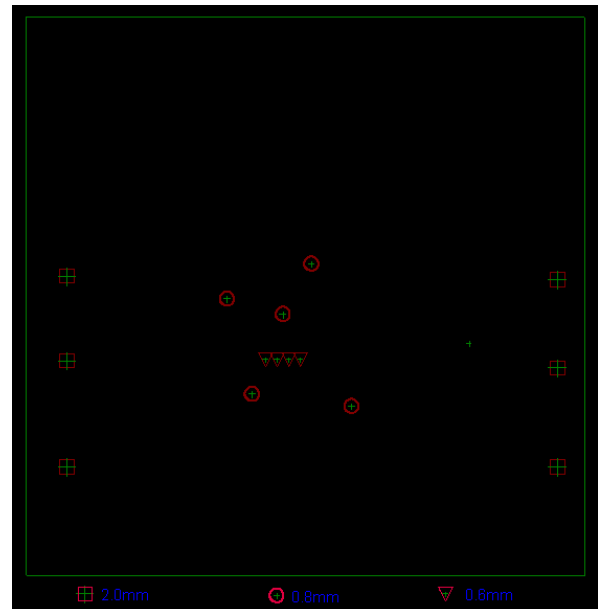

Drill File

NOTES

NOTES

Definitions

Product change

Zetex Semiconductors reserves the right to alter, without notice, specifications, design, price or conditions of supply of any product or service. Customers are solely responsible for obtaining the latest relevant information before placing orders.

Applications disclaimer

The circuits in this design/application note are offered as design ideas. It is the responsibility of the user to ensure that the circuit is fit for the user's application and meets with the user's requirements. No representation or warranty is given and no liability whatsoever is assumed by Zetex with respect to the accuracy or use of such information, or infringement of patents or other intellectual property rights arising from such use or otherwise. Zetex does not assume any legal responsibility or will not be held legally liable (whether in contract, tort (including negligence), breach of statutory duty, restriction or otherwise) for any damages, loss of profit, business, contract, opportunity or consequential loss in the use of these circuit applications, under any circumstances.

Life support

Zetex products are specifically not authorized for use as critical components in life support devices or systems without the express written approval of the Chief Executive Officer of Zetex Semiconductors plc. As used herein:

- A. Life support devices or systems are devices or systems which:
 1. are intended to implant into the body

or

- 2. support or sustain life and whose failure to perform when properly used in accordance with instructions for use provided in the labeling can be reasonably expected to result in significant injury to the user.
- B. A critical component is any component in a life support device or system whose failure to perform can be reasonably expected to cause the failure of the life support device or to affect its safety or effectiveness.

Reproduction

The product specifications contained in this publication are issued to provide outline information only which (unless agreed by the company in writing) may not be used, applied or reproduced for any purpose or form part of any order or contract or be regarded as a representation relating to the products or services concerned.

Terms and Conditions

All products are sold subjects to Zetex' terms and conditions of sale, and this disclaimer (save in the event of a conflict between the two when the terms of the contract shall prevail) according to region, supplied at the time of order acknowledgement. For the latest information on technology, delivery terms and conditions and prices, please contact your nearest Zetex sales office.

Quality of product

Zetex is an ISO 9001 and TS16949 certified semiconductor manufacturer. To ensure quality of service and products we strongly advise the purchase of parts directly from Zetex Semiconductors or one of our regionally authorized distributors. For a complete listing of authorized distributors please visit: www.zetex.com/salesnetwork Zetex Semiconductors does not warrant or accept any liability whatsoever in respect of any parts purchased through unauthorized sales channels.

ESD (Electrostatic discharge)

Semiconductor devices are susceptible to damage by ESD. Suitable precautions should be taken when handling and transporting devices. The possible damage to devices depends on the circumstances of the handling and transporting, and the nature of the device. The extent of damage can vary from immediate functional or parametric malfunction to degradation of function or performance in use over time. Devices suspected of being affected should be replaced.

Green compliance

Zetex Semiconductors is committed to environmental excellence in all aspects of its operations which includes meeting or exceeding regulatory requirements with respect to the use of hazardous substances. Numerous successful programs have been implemented to reduce the use of hazardous substances and/or emissions. All Zetex components are compliant with the RoHS directive, and through this it is supporting its customers in their compliance with WEEE and ELV directives.

Product status key:

- "Preview" Future device intended for production at some point. Samples may be available
- "Active" Product status recommended for new designs
- "Last time buy (LTB)" Device will be discontinued and last time buy period and delivery is in effect
- "Not recommended for new designs" Device is still in production to support existing designs and production
- "Obsolete" Production has been discontinued

Datasheet status key:

- "Draft version" This term denotes a very early datasheet version and contains highly provisional information, which may change in any manner without notice.
- "Provisional version" This term denotes a pre-release datasheet. It provides a clear indication of anticipated performance. However, changes to the test conditions and specifications may occur, at any time and without notice.
- "Issue" This term denotes an issued datasheet containing finalized specifications. However, changes to specifications may occur, at any time and without notice.

Europe	Americas	Asia Pacific	Corporate Headquarters
Zetex GmbH Kustermann-park Balanstraße 59 D-81541 München Germany Telefon: (49) 89 45 49 49 0 Fax: (49) 89 45 49 49 49 europe.sales@zetex.com	Zetex Inc 700 Veterans Memorial Highway Hauppauge, NY 11788 USA Telephone: (1) 631 360 2222 Fax: (1) 631 360 8222 usa.sales@zetex.com	Zetex (Asia Ltd) 3701-04 Metroplaza Tower 1 Hing Fong Road, Kwai Fong Hong Kong Telephone: (852) 26100 611 Fax: (852) 24250 494 asia.sales@zetex.com	Zetex Semiconductors plc Zetex Technology Park, Chadderton Oldham, OL9 9LL United Kingdom Telephone (44) 161 622 4444 Fax: (44) 161 622 4446 hq@zetex.com

© 2006 Published by Zetex Semiconductors plc.